

# Model 16

Digital Sound Level Meter User Manual



## About this manual

The instructions in this user manual refer to the operation of Pulsar Instruments plc MODEL 16 and MODEL 16 entry-level sound level meters.

The instruments described in this manual are the MODEL 16 and MODEL 16.

This manual describes the recommended usage of the MODEL 16 and MODEL 16. Any warnings will be indicated by the following symbol:



It is not possible to change the way that the instrument measures through software or firmware. Any legal metrology aspects of the instrument cannot be affected by any changes made in the instrument.

---

---

## Copyright

Copyright © Pulsar Instruments plc 2025

All rights reserved.

You may re-use this document/publication (not including the Pulsar Instruments plc logo and other product logos) free of charge in any format for research, private study or internal circulation within an organisation. You must re-use it accurately and not use it in a misleading context.

You must not modify text, images or illustrations in any way. The material must be acknowledged as Pulsar Instruments plc copyright, and you must give the title of the source document/publication.

Where any third-party copyright material is identified, you will need to obtain permission from the copyright holders concerned.

### Trademarks

Pulsar Instruments plc and the Pulsar Instruments plc Logo are either registered trademarks or trademarks of Pulsar Instruments plc in the United Kingdom and/or other countries. Microsoft and Windows are registered trademarks of Microsoft, Inc. All other trademarks acknowledged.

### Updates

In the interests of continuous product improvement, Pulsar Instruments plc reserves the right to make changes to product specifications without notice.

To understand the latest updates that have been implemented into this product and to download the most current version of this user manual, visit our website at <https://pulsarinstruments.com/software-downloads/>

Revision 1 | December 2025

---

---

## Contents

1	Introduction .....	5
2	First use.....	6
3	Instrument overview .....	7
4	Instrument displays.....	9
4.1	MODEL 16 main display.....	9
4.2	Calibration display .....	9
4.3	MODEL 16 alarm set display.....	10
5	Instrument keypad.....	11
6	Instrument operation .....	12
6.1	Selecting the frequency and time weighting .....	12
6.2	Maximum, minimum and LCPeak values .....	12
6.3	Setting the level alarm .....	12
7	Instrument calibration.....	14
8	Specifications and technical information .....	15
8.1	Instrument specifications.....	15
8.2	Reference information for periodic testing.....	15
9	Options and accessories.....	19
10	Serial connection .....	20
11	Declaration of Conformity.....	21
12	Product guarantee and extended warranty .....	22
13	Pulsar Instruments contact details .....	23

---

---

## 1 Introduction

Welcome to your new MODEL 16 digital noise meter.

The MODEL 16 is a general-purpose digital sound level meter designed to IEC 61672 Class 2. The instrument has 'F' (fast) and 'S' (slow) time response and 'A' and 'C' frequency weightings. Additional features include max and min hold for the measurement duration, LCpeak, and limit alarm, which you can configure to indicate if your set threshold has been exceeded.

---

## 2 First use

Before using your meter for the first time, please check the contents of your instrument's case, which should include the following:

- Sound level meter and Class 2 microphone
- Windshield
- 2 x AA batteries

Optional accessories

- Class 2 acoustic calibrator

You may have other accessories, depending on your package.



Before starting a measurement, remove the black microphone protective cap (if fitted) and where necessary, place the windshield carefully over the end of the microphone capsule.

### 3 Instrument overview





## 4 Instrument displays

### 4.1 MODEL 16 main display

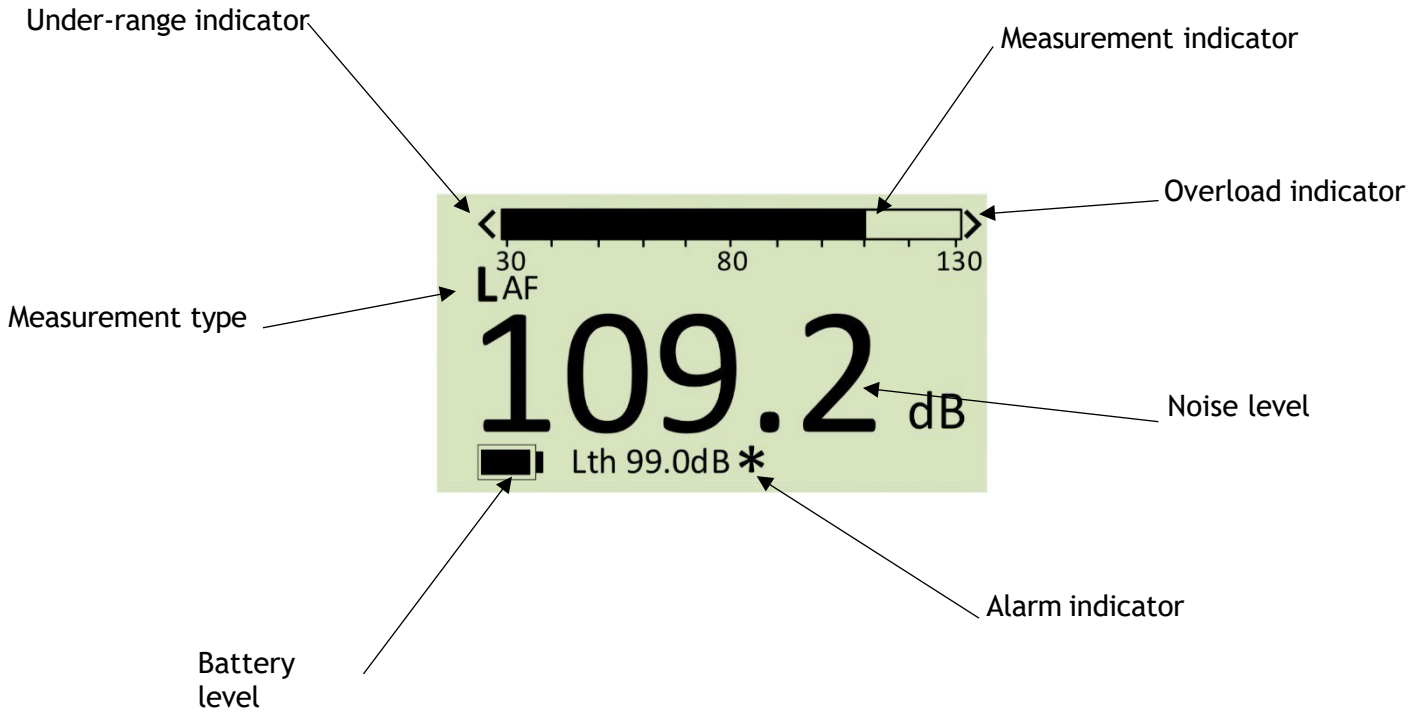

### 4.2 Calibration display

Press the CAL button.

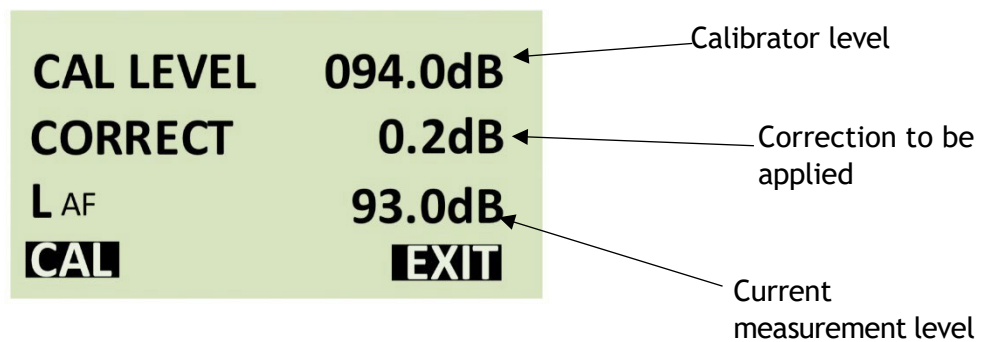

### 4.3 MODEL 16 alarm set display

Press  .

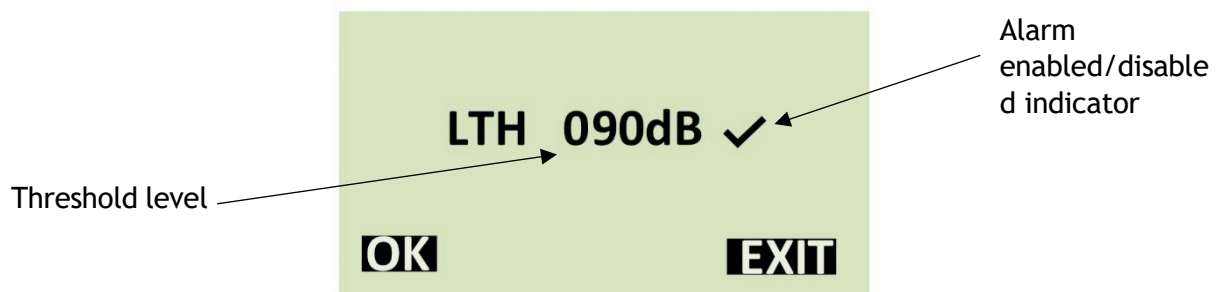

## 5 Instrument keypad

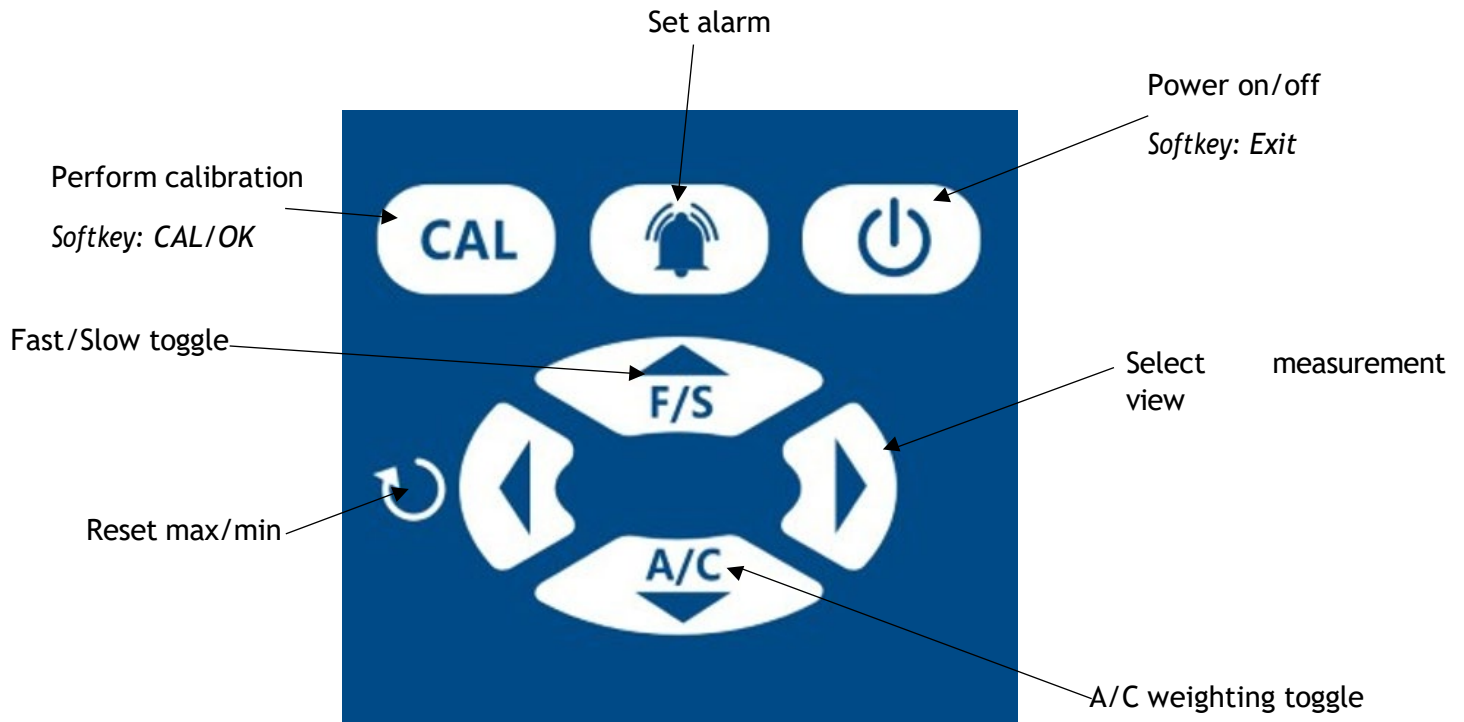

## 6 Instrument operation

Fit new batteries by sliding the battery cover open and inserting two AA batteries in the correct orientation.

Switch on and allow the instrument to settle for 60 seconds before calibrating.

Before starting a measurement, calibrate the instrument as per the guidance in Section 7 of this user manual.

### 6.1 Selecting the frequency and time weighting

Select the measurement frequency and time weighting required:

To toggle between A and C weighting, press  .

To toggle between fast and slow weighting, press  .

The measurement type is displayed in the main window:

LAF - A frequency weighting | fast time weighting

LCF - C frequency weighting | fast time weighting

LAS - A frequency weighting | slow time weighting

LCS - C frequency weighting | slow time weighting

To toggle the measurement values, press  . This will toggle through the following measurement values if the meter is set to LAF:

LAF > LAFMax > LAFMin > LCPeak > LAF

Integrating averaging measurements Lxeq1s and Lxeq8h are available on the MODEL 16 instrument.

### 6.2 Maximum, minimum and LCPeak values

Maximum, minimum and LCPeak values are shown for the duration of time since the meter was switched on or since the reset button was last pressed.

These values can be reset by pressing  .

### 6.3 Setting the level alarm

The level alarm function can be used to trigger an alert if the noise level exceeds a predetermined value, which is set by you.

To set the alarm level, press  to enter the alarm setup display.



Set the desired level and enabled the alarm by using the arrow buttons. A tick denotes that the alarm is active; a cross denotes that the alarm is disabled. When set, press  to confirm.

*NB: the alarm level should not be set to less than 129dB.*

With the alarm enabled, the main display will indicate that the level has been exceeded by showing an asterisk (\*) next to the sound level reading. The triggered threshold value can be reset by pressing .

*NV: this will also reset the maximum, minimum and LCPeak measurement values.*

## 7 Instrument calibration

Before each measurement, it is important to calibrate your instrument with an acoustic calibrator, such as the Pulsar Instruments MODEL106 1kHz 94dB calibrator.

To start the process of calibration, ensure the microphone is fitted correctly and place the acoustic calibrator over the microphone.

Press  enter the calibration menu.

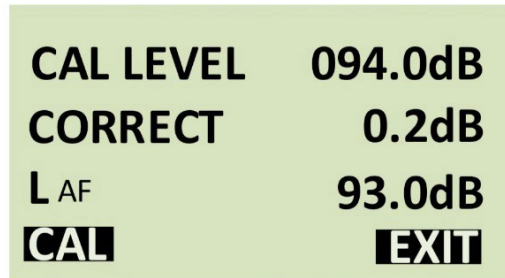

The image shows a calibration menu on a light green background. The text is as follows:

<b>CAL LEVEL</b>	<b>094.0dB</b>
<b>CORRECT</b>	<b>0.2dB</b>
<b>L AF</b>	<b>93.0dB</b>
<b>CAL</b>	<b>EXIT</b>

Use the arrow keys to set the CAL LEVEL to the acoustic calibration level (94.0dB for the MODEL106 calibrator).

Use the arrow keys to set the CORRECT value to 0.2dB, which will make the adjustment for the gap between the calibrator and the microphone (pressure field of the acoustic calibration and the free field of the instrument and microphone (HY:205 microphone).

This will result in the meter reading 93.8dB when a 94dB calibrator is used.

Switch on the acoustic calibrator and insert the microphone capsule into the cavity on the calibrator. Take care to not force the microphone, as this could cause damage to either the instrument or the calibrator.

Press  to automatically calibrate the meter.

Press  to exit from the calibration display and return to the main display.

## 8 Specifications and technical information

### 8.1 Instrument specifications

Applicable standards	IEC 61672-1: 2013 Class 2
Measurement range	30dB(A) - 130dB(A) 40dB(C) - 130dB(C)
Frequency weighting	A and C
Time weighting	Fast (F) and Slow (S)
Display functions	Normal, Maximum, Minimum, CPeak
Measurement functions	LAF, LAS, LCF, LCS, LCPeak
Noise floor	<25dB(A) and 35dB(C)
Display flags	Alarm limit, overload and under-range
Auto calibration range	±4.5dB
Reference point	94dB (1kHz), 92.9dB (8kHz)
Settling time	60s
Display	Backlit 128x64 LCD
Resolution	0.1dB
Electrical input	5V power-in via mini-USB
Power	2 x AA/LR6 1.5V batteries or 5V DC via mini-USB input
Battery life	24 hours with alkaline batteries
Microphone	½” pre-polarised electret condenser type HY:205
Operating temperature	0° C to +40° C
Operating humidity	25% - 90%
Atmospheric pressure	65kPa - 108kPa
Storage temperature	-20° C to +60° C
Dimensions	215mm x 68mm x 32mm
Weight (including batteries)	220g
Electrical outputs	Standard 3.5mm stereo jack AC (tip 3.5mm jack), DC (middle ring 3.5mm jack), GND (outer ring 3.5mm jack)
DC output	DC voltage per indicated noise level (A or C frequency weighting) Voltage 15mV/dB, range 450mV - 1950mV Recommend maximum load resistance is greater 1MΩ to minimize attenuation
AC output	AC voltage per Z-weighted measured RMS 2V rms max

### 8.2 Reference information for periodic testing

Reference level (1kHz)	94dB
Reference level (8kHz)	92.9dB(A)
Linear range 8kHz	30 - 130dB
Linear range 4kHz	30 - 130dB
Linear range 1kHz	30 - 130dB
LCPeak maximum (500Hz, 1kHz, 8kHz)	133dB
Self-generated noise floor	A-weighting = 25dB C-weighting = 35dB
Self-generated noise floor (with mic fitted)	A-weighting = 25dB C-weighting = 35dB

---

Dummy microphone capacitance	18pf
Recommended dummy microphone	KP:66

---

### 8.2.1 Multifrequency acoustic calibrator correction data (set to pressure and test on A- weighting)

Frequency	Correction
125Hz	0.0
1kHz	0.2
8kHz	2.6

### 8.2.2 Free field correction for HY205 microphone

Frequency (kHz)	Free field correction (dB)	Frequency (kHz)	Free field correction (dB)
1	0.1	6.3	1.7
1.25	0.1	8	2.6
1.6	0.2	10	4.4
2	0.3	12.5	5.3
2.5	0.5	16	6.5
3.15	0.7	18	7.1
4	1.0	20	7.8
5	1.4	---	---

### 8.2.3 Case reflection and windshield attenuation data

Frequency (kHz)	Case correction	Windshield correction	Uncertainty
63	0	0	0.27
125	0	0	0.27
250	0.13	0.05	0.27
500	0.18	0.08	0.27
1000	0.09	0.1	0.27
2000	-0.16	0.26	0.27
4000	0.01	0.53	0.32
8000	-0.10	0.26	0.30
16000	-0.17	-0.58	0.29

Add the above data to your measurement to correct.

### 8.2.4 Directionality plots and case reflection points

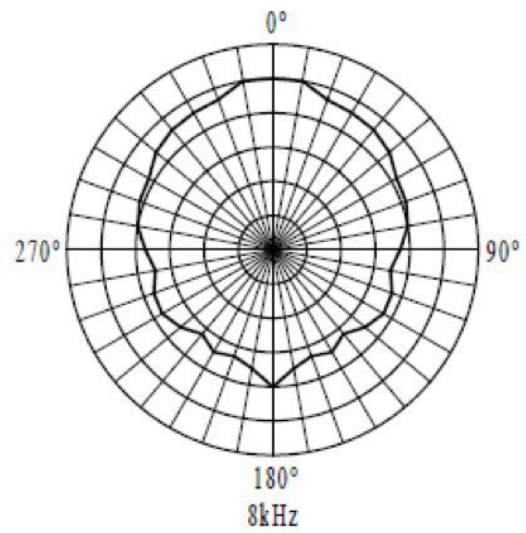
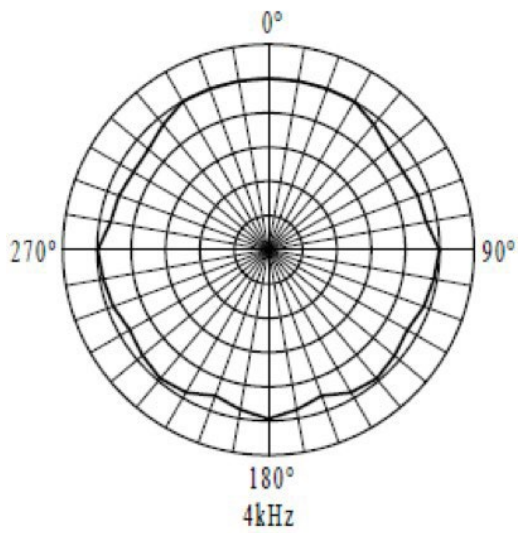
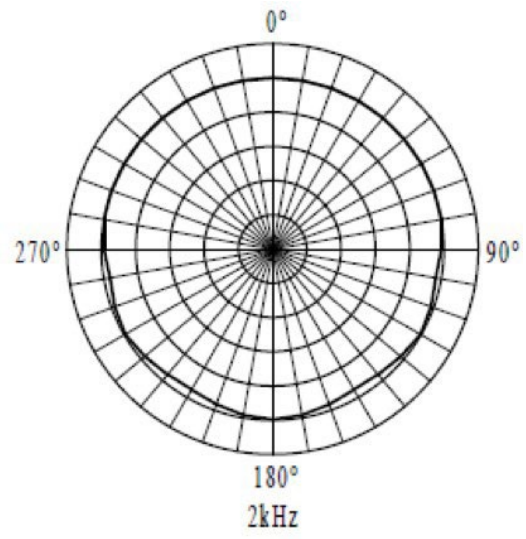
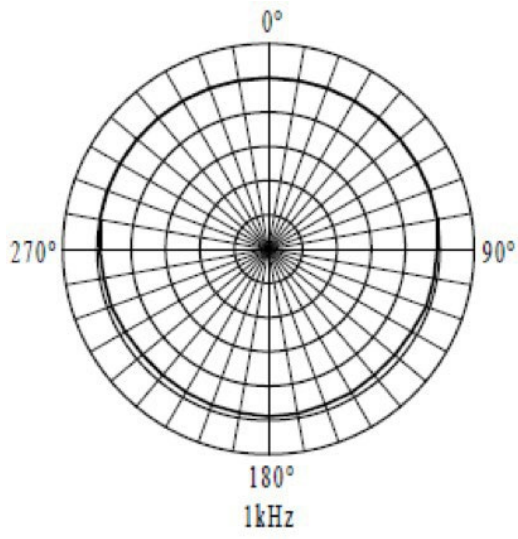

## 9 Options and accessories

The following table contains information about the model options and accessories available with this sound level meter.

Pulsar Instruments part number	Descriptions
MODEL 16	Basic sound level meter with threshold
MODEL106	Acoustic calibrator
CK380	Kit case (empty)
MODEL16K	MODEL 16 kit including case, meter and calibrator
UA30X	Spare windshield
CP1	Carrying pouch for sound level meter and calibrator

## **10 Serial connection**

DB9, RS232 communications rate at 9600 Baud.

1 bit start, 8 bits data, 1 bit stop, no parity.

---

## 11 Declaration of Conformity

Manufacturer: Pulsar Instruments plc  
Unit 2  
Hunmanby Industrial Estate  
Hunmanby  
North Yorkshire  
YO14 0PH  
United Kingdom



Telephone: +44 (0)1723 339715

Equipment manufactured after January 2026.

Equipment description

MODEL 16 sound level meter

According to:

EMC Directive 2014/30/EU  
Low Voltage Directive 2014/35/EU  
RoHS Directive 2011/65/EU

Meet the following standards:

EN 61000-6-3: 2007+A1: 2011  
Electromagnetic compatibility (EMC). Generic standards. Emission standard for residential, commercial and light- industrial environments.

EN 61000-6-1: 2007  
Electromagnetic compatibility (EMC). Generic standards. Immunity for residential, commercial and light- industrial environments.

Signed

Friday, 18 December 2025

A handwritten signature in black ink, appearing to read 'MJS', is positioned above the printed name of the signatory.

Martin Williams  
Director



## **12 Product guarantee and extended warranty**

1. Every new product is provided with a 12-month warranty. This covers everything we provide against failure, poor workmanship and accidental damage.

NB - European Union law states a product must be fit for purpose for 24 months after purchase. This two-year period covers failure and poor workmanship only.

2. If the product is calibrated by Pulsar Instruments or an authorised calibration and service centre, then the initial 12-month warranty is extended by a further 12 months, with the same conditions, for up to 7 years in total.

3. If a product has not been calibrated annually by Pulsar Instruments or an authorised calibration and service centre, then you may buy back into the warranty scheme for £100 plus the cost of calibration. This can only be done once during the life of the product.

4. If a microphone capsule fails under warranty and is physically damaged, we will replace it with a refurbished capsule.

5. If you don't wish to have a refurbished capsule, please let us know and we will provide a quotation for the trade-in of the damaged capsule and the cost of a new microphone.

---

---

## 13 Pulsar Instruments contact details

In addition to independent sales channels in the UK, Pulsar Instruments also operates through approved distributors and agents in many countries worldwide. For details of your local representative, please contact Pulsar Instruments using the information below. Contact details for Pulsar Instruments authorised distributors and agents are also available from the website at the address shown below.

Pulsar Instruments plc  
Unit 2  
Hunmanby Industrial Estate  
Hunmanby  
North Yorkshire  
United Kingdom  
YO14 0PH

T: +44 (0)1723 339715

E: [sales@pulsarinstruments.com](mailto:sales@pulsarinstruments.com)

W: <https://pulsarinstruments.com/>

---

## Notes

## Notes

## Notes

## Notes



[pulsarinstruments.com](http://pulsarinstruments.com)  
[sales@pulsarinstruments.com](mailto:sales@pulsarinstruments.com)